

Weyn-Lauwers N.V.

Industriepark-Noord 12
B - 9100 SINT-NIKLAAS

Tel. : 00 32 (0)3 776.34.13
Fax : 00 32 (0)3 778.09.52
weynlauwers@weynlauwers.be
www.weynlauwers.be

FORGED GLOBE VALVE
NPT - 800LBS
stainless steel
FIG 427

DESIGN FEATURES

- forged globe valve 3/8"-2"
- **threaded NPT**
- min. temp : -30°C
- max. temp : +440°C
- specifications : rising stem
bolted bonnet
gland pack
reduced bore

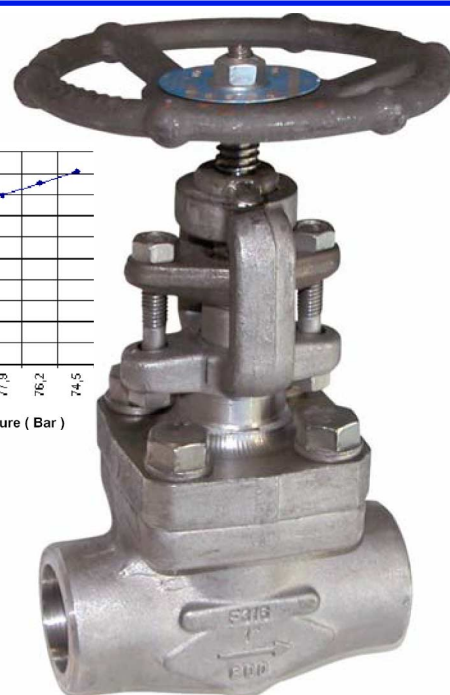
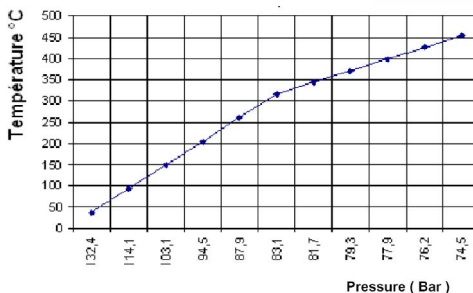

USE

- for all common fluids max. press. 138 bar

MATERIALS

item	Part name	Material
1	wheel nut	carbon steel
2	name plate	aluminium
3	handwheel	carbon steel
4	Yoke nut	ASTM A582 type 416
5	Gland nut	ASTM A194 2H
6	Gland flange	ASTM A182 F304
7	Gland stuk	ASTM A193 B8
8	Gland	ASTM A479 type 304
9	packing	graphite
10	bolts	ASTM A193 B8
11	stem	ASTM A479 type 316
12	bonnet	ASTM A182 F316
13	gasket	SS316+graphite spiral w.
14	seat	ASTM A479 type 316
18	body	ASTM A182 F316
19	disc	ASTM A479 type 316

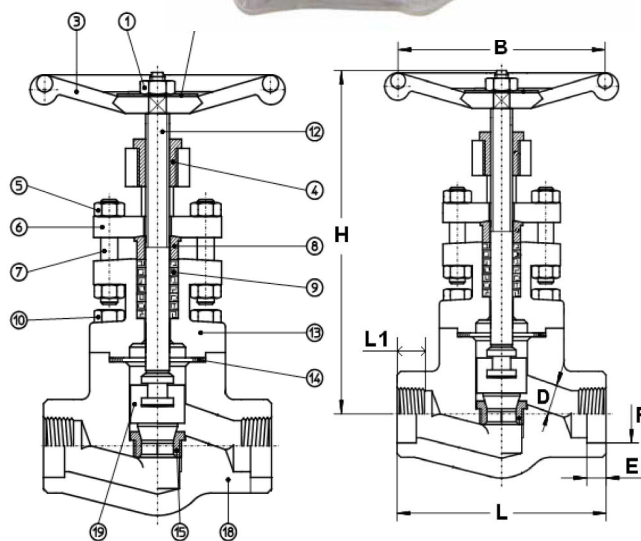

SIZE (in mm)

DN	3/8"	1/2"	3/4"	1"	1 1/4"	1 1/2"	2"			
D	9	9	13	17,5	22,5	29,5	35			
L	80	80	90	110	127	155	170			
H open	148	148	165	180	213	248	257			
B	90	90	90	110	130	130	180			
L1	13	15	18	19	20	21	21			
Kv m3h	1,2	1,3	3,3	5,9	9,5	12,4	21,6			
kg	1,9	1,9	2,18	3,52	5,30	7,30	11,3			
ref.	427.03	427.04	427.05	427.06	427.07	427.08	427.09			